

18" Scupper with Black Coated Frame

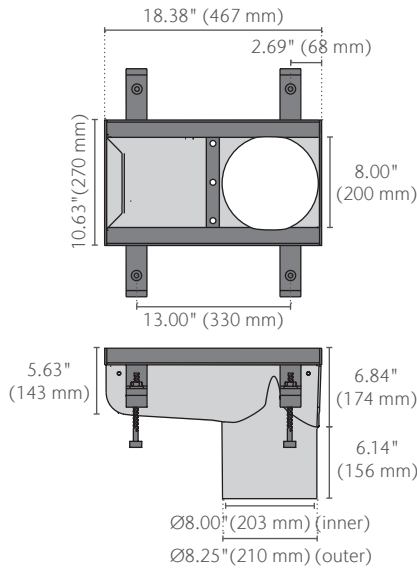

Outlet Flow Rates

Outlet	Outlet Size	Invert Depth in (mm)	GPM	CFS
A	8.00" ID Pipe	6.60 (168)	516	1.15

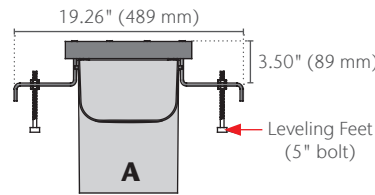

Product Name	Part No.	Length in (mm)	Invert Depth (Female) in (mm)	Invert Depth (Male) in (mm)	Weight lbs
18" Scupper with Black Coated Frame	95349	18.38(467)	5.51(140)	6.60(167)	42.5

Specification Summary

General

The scupper shall be ACO Infrastructure BridgeDrain Scuppers as manufactured by ACO, Inc. or equal approved.

Grates

See separate ACO Spec Info sheets for details.

Installation

The surface drain system shall be installed in accordance with the manufacturer's installation instructions and drawings.

Materials

The scupper bodies shall be manufactured from polyester fiberglass, with minimum properties as follows:

- Compressive strength: 24,400 psi
- Flexural strength: 9,943 psi
- Water absorption 0.33%
- Frost-proof
- Salt-proof: B117 Salt Spray Test compliant
- Dilute acid and alkali-resistant

The nominal clear opening shall be 8.00" (203 mm) with overall width of 10.63" (270 mm). Units shall be manufactured with a sloped invert and have a wall thickness of at least 0.125" (3 mm). Each unit will feature a 8.00" (203 mm) outlet pipe. The fiberglass channel body shall be fixed to the frame using push fit nylon studs. Overall length shall be 18.38"(467 mm). Frames shall be manufactured from minimum 0.188" (5 mm) thick black powder coated steel and incorporate leveling feet to ensure correct and easy installation; leveling feet also act as concrete anchors to ensure maximum mechanical bond to surrounding bedding material and pavement surface.

EN1433 Load Class E
134,885 lbs – 2,785 psi

ACO, Inc.

© January 2026 ACO, Inc.

All reasonable care has been taken in compiling the information in this document. All recommendations and suggestions on the use of ACO products are made without guarantee since the conditions of use are beyond the control of the company. It is the customer's responsibility to ensure that each product is fit for its intended purpose and that the actual conditions of use are suitable. ACO, Inc. reserves the right to change products and specifications without notice.

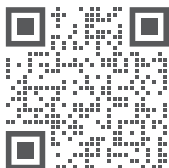

info@acousa.com
www.acousa.com

